

KVIR-P

NEW

Air sanitation modules WITH PLASMA TECHNOLOGY AND ANTI-VIRUS FILTER from 400 to 16,000 m³/h

KVir-P modules are designed for easy installation, **even within an existing aeraulic system**, of a sanitising section of the treated air.

KVir sanitation modules use two technologies:

1. Photocatalysis with plasma UV. The innovative high intensity dual wavelength UV lamps generate plasma, i.e. a gaseous mixture charged with energy.
2. Antivirus post-filtration (ePM1 55%). The new T-abv filters block allergens, bacteria and viruses from the airflow.

The wide range of flow rates covers the most varied residential, tertiary and industrial applications.

The series is divided into six sizes, for air flows ranging from 400 to 16,000 m³/h.



OFFICES



RESTAURANTS



SHOPS

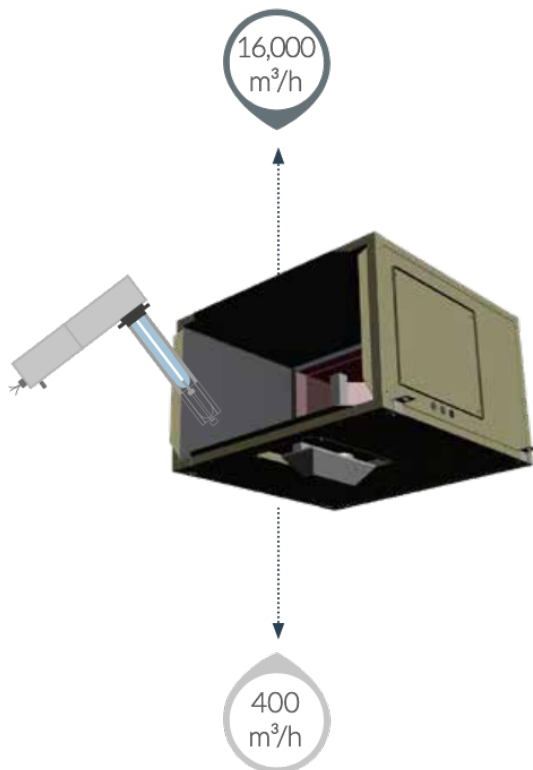

PLUG&PLAY



INDOOR
INSTALLATION



HORIZONTAL
ORIENTATION



VERTICAL
ORIENTATION

FLEXIBILITY DURING INSTALLATION

Flexibility of insertion of the KVir-P module, even in an existing aeraulic system, thanks to a dedicated and autonomous controller.

TECHNICAL SPECIFICATIONS AND ACCESSORIES

- UVC lamp, with very low energy consumption (<24W/lamp) and immersed in the air flow, contained in a sandwich box
- Containment structure with interior in AISI 304 stainless steel and exterior in pre-painted sheet metal, insulation with high density mineral wool
- Low voltage supply from a directly connected external heatsink module
- Easily removable assembly for standard maintenance and lamp(s) replacement operations at the end of the operating cycle (approximately 9000 hours).
- On-board controller for system management, with display, with the following features:
 - digital input for remote on/off (typically from the handling or ventilation unit to which it is paired)
 - visual (non-critical) maintenance alarm (lamp life low)
 - visual post-filter clogging alarm (if present), available as digital output (in common with lamp signal)
 - duty-cycle management that can be set by the user based on specific needs of the application.

PLASMA TECHNOLOGY DESCRIPTION

KVir-P is the new range of modules which can be installed in pre-treated inlet air ducts to sanitise/purify the air with plasma technology to reduce bacterial/viral loads for a quick and effective sanitation and disinfection. This technology is based on the principle of plasma photocatalysis, an innovative process that uses light sources to purify the air, without adding / emitting chemical agents into the atmosphere.

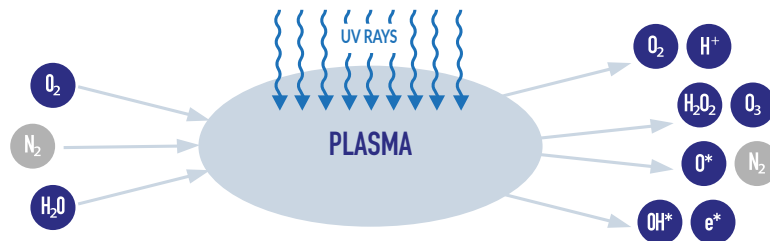

KVir-P uses innovative high intensity dual wavelength UV lamps that generate plasma, i.e. a gaseous mixture charged with energy and containing O⁺, O⁻, O₂, O, O₃, ionised O₂, metastable excited O₂ and free electrons. Plasma has the following effects:

- It breaks the carbon molecular chains found in polluting compounds, with the result of eliminating odours;
- At the same time, the hydrogen atoms (generated by the splitting of moisture - H₂O - of the air, combined with free oxygen atoms - O₂), create free radicals suitable for the oxidation of contaminants (odours, viruses, bacteria, greases and other organic substances) and to disinfect air and surfaces.

The plasma created, unlike other sanitising technologies, acts with 5 different forms of technologies for purification:

1. photo-plasma
2. photocatalytic oxidation
3. UV sterilisation
4. production of negative ions
5. controlled ozone production to attack chemical and biological contaminants, in particular to destroy the cell membrane and the DNA of microorganisms such as viruses, bacteria, fungi with an efficiency greater than 99% in less than a minute and break the chemical bonds of the most common pollutants (e.g. nicotine, VOC, ammonia).

KVir-P also uses antivirus post-filtration technologies with new T-abv filters (ePM1 55%) that block allergens, bacteria and viruses from the air flow, thanks to a non-toxic polymeric substance applied to the surface of the individual fibres of the micro-glass filtration material. The pressure drop of these filters is negligible.

MODELS AND TECHNICAL DATA

KVIR-P		1000	2500	4000	6500	10000	16000	
	nominal	750	1900	3100	4900	8200	12500	
Airflow	minimum	400	1000	2000	3000	5000	8000	
	maximum	1000	2500	4000	6500	10000	16000	
Air pressure drop (1)		Pa		10 / 90				
ELECTRICAL ABSORPTION								
Absorbed power (1)		W	15 / 50	20 / 110	2 x 20 / 200	2 x 24 / 300	3 x 24 / 500	3 x 24 / 700
Power supply		V-ph-Hz	230-1-50					
SANITISING CAPACITY								
Average viral load reduction (2)		%	> 98					
Elimination of bacterial load (3)		%	> 97					
Average VOC reduction (4)		%	50					
Optional post-filter efficiency (5)		%	> 98					

(1) without / with post-filter at nominal flow rate;

(2) referred to hPIV-3 parainfluenza virus sample;

(3) referred to airborne Enterobacter;

(4) test substances: Toluene, Xylene, Butyl acetate;

(5) referred to particles with a diameter of 10 nm;

DIMENSIONS AND WEIGHTS

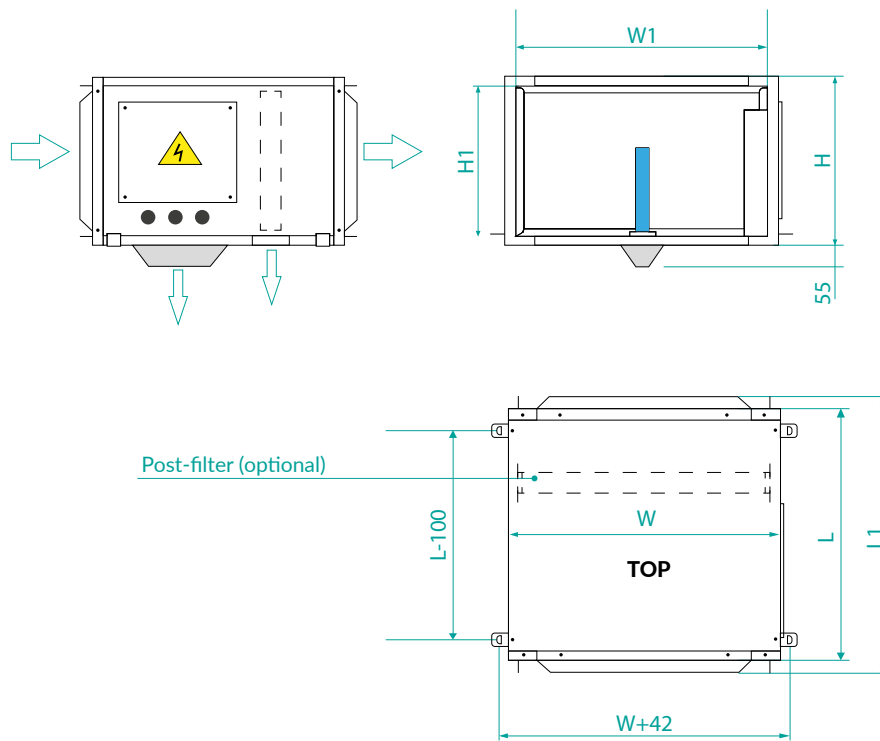

MODEL		1000	2500	4000	6500	10000	16000
L	mm	600	600	600	600	600	600
H	mm	300	400	400	500	600	900
W	mm	450	650	1050	1400	1900	2000
L1	mm	660	660	660	660	660	660
H1	mm	258	358	358	458	558	858
W1	mm	402	602	1002	1352	1852	1952
Weight	kg	11	14	19	24	35	45